

SAMSON

GLOBE CONTROL VALVE TYPE 3241

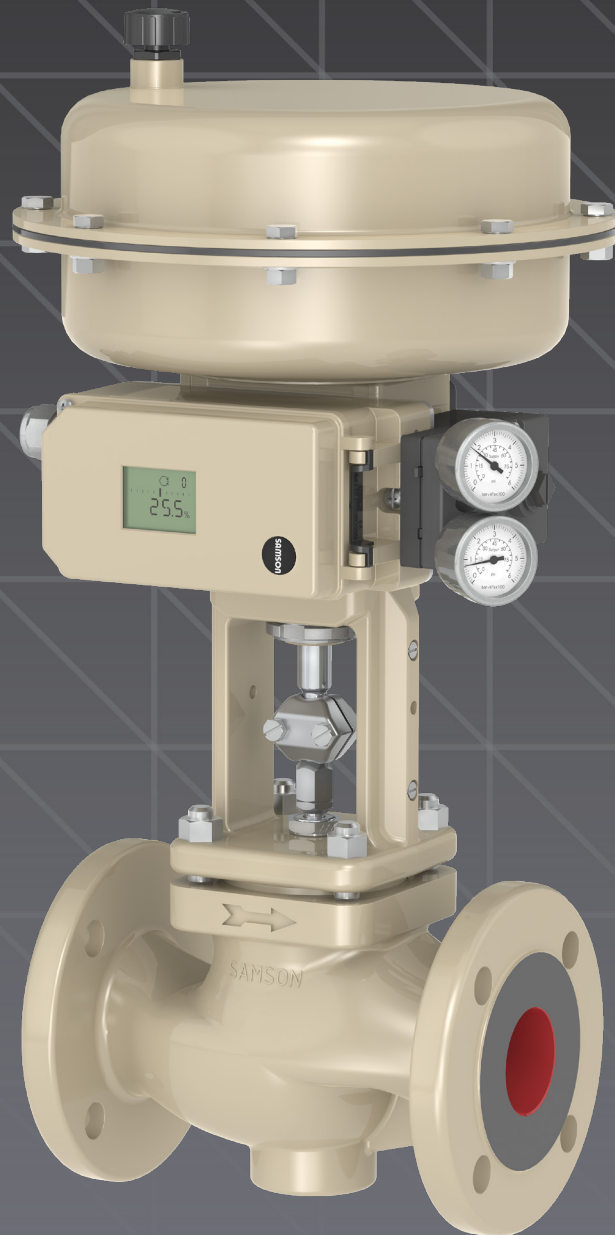

SAMSON – OUR EXPERTISE

Engineered Solutions From a Single Source

Combined with valve accessories, control valves serve as engineered solutions for many process control applications. SAMSON has been developing and manufacturing high-quality valves, actuators and valve accessories for over 100 years. Our experience and expertise allows us to continuously develop our products to provide a complete solution for your application.

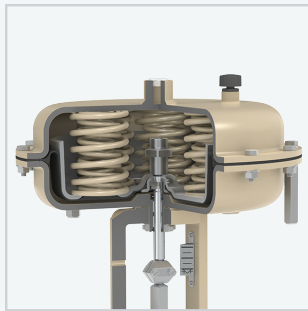

ACTUATORS



POSITIONERS



LIMIT SWITCHES



SOLENOID VALVES

Economical Total Cost of Ownership

The modular design of our products allows for a tailor-made solution while utilizing readily available components. Furthermore, the interchangeability of spare parts between different valve models and sizes contributes to low inventory management and costs.

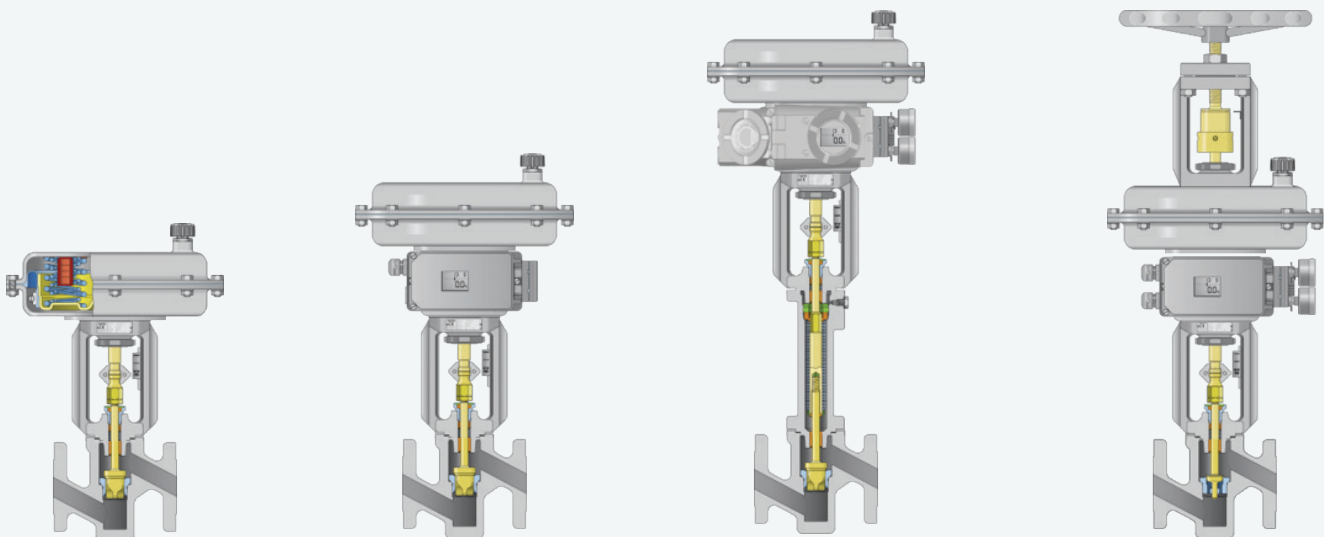

Thanks to the combination of our trusted engineering and modular design, SAMSON can offer long-lasting equipment, as well as reduced capital and operating costs.

FEATURES AND BENEFITS

Integrated Accessory Attachment

- Eliminates external tubing
- Protects mechanical feedback linkage
- Entire actuator top works can be rotated 360° without disassembly

SAMSON Smart Devices

- Easy push-button positioner initialization
- Intrinsically safe & explosion proof options available
- EXPERTPlus Diagnostics

Self-adjusting PTFE V-ring Packing

- Maintenance-free design
- Low friction
- Roller burnished stem reduces friction, external leakage, and maximizes packing life beyond what basic polishing can offer from competitors.

Patented Multi-layered Bellows Technology

- Double wall design
- Small valve travel results in a long bellows life
- Modular design allows for the addition or removal of bellows in the field

Straight Thread Seat Design

- No cage, gaskets or seals required
- Fewer spare parts required for maintenance
- Easy removal even after many years of service

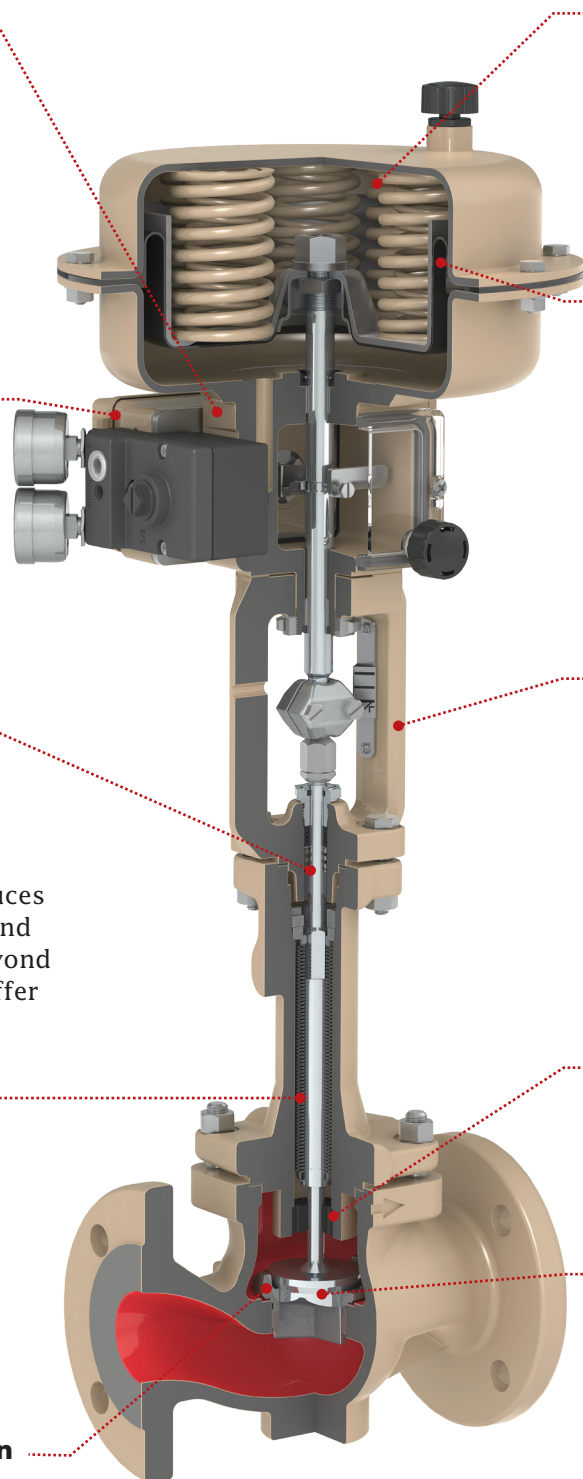

Field Reversible Nested Multi-Spring Actuator

- Reduced height and weight
- Easily convert between fail actions in the field with minimal effort

Rolling Diaphragm

- Greatly reduces diaphragm wear compared to stretching diaphragm design used by competitors.
- Diaphragm design results in very small external air loss

Single Bonnet/Yoke Design

- Actuator removal without the need to open the valve
- Bonnet and body of the valve always have same metallurgy
- Fewer components results in a lower profile valve assembly

Low Lying Guide Bushing

- Ensures precise plug alignment for our stem guided trim

Multiple Plug Designs

- Parabolic - Cost effective & debris friendly
- V-Port - Reduced vibration & debris friendly
- Perforated - Vibration reduction and flow dispersion

Various Noise Attenuation Options

- Flow Divider I, II, & III (Gases/Vapors)
- Anti-Cavitation Trims (Liquids)
- Optional downstream orifice plates

INTERNAL STRENGTH

Trim For Every Application

Obstacles hindering accurate process control can be numerous. The 3241 comes equipped with a wide range of available trim options to overcome difficult to control applications.

- Parabolic Plug
- V-Port Guided Plug
- Perforated Plug
- Multi-Stage Trim
- Noise Attenuation Trim



Noise Reduction – When not getting noticed is a good thing

A flow divider is an optional internal device used with gases and vapors to help reduce the sound pressure level (SPL) of a valve. By creating an additional stage of pressure reduction inside the valve, it breaks a single large flow stream into multiple smaller flow streams, resulting in reduced noise emissions.

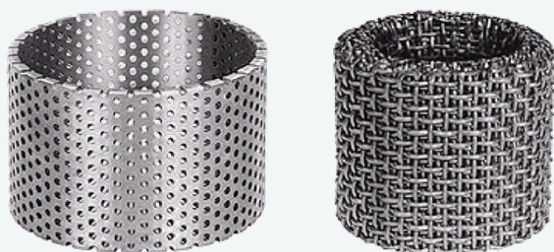

Three versions of flow dividers are available, based on the amount of noise reduction required. Depending on flow conditions, noise reductions of up to 30 dB(A) can be achieved.

Packing – The 1st line of defense

- Standard spring-loaded V-ring packing
 - Maintenance free & self adjusting
- Pure graphite or pure PTFE options
- Adjustable packing options
- Emission standards
 - ANSI / FCI 91-1 (EPA Method 21)
 - ISO 15848
 - TA-Luft / VDI 2440
 - Shell SPE 77/312

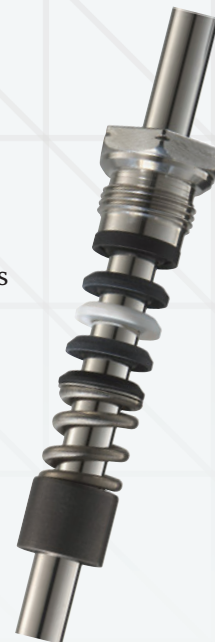

Bellows Seal – Nothing left to chance

Many plants rely on toxic or highly reactive compounds for their processes, these compounds can present an inherent health and/or safety hazard and must be contained.

SAMSON's bellows seal technology is the leader in design and performance.

The bellows seal helps ensure fugitive emissions are contained and leaks to the atmosphere are minimized down to near zero levels.

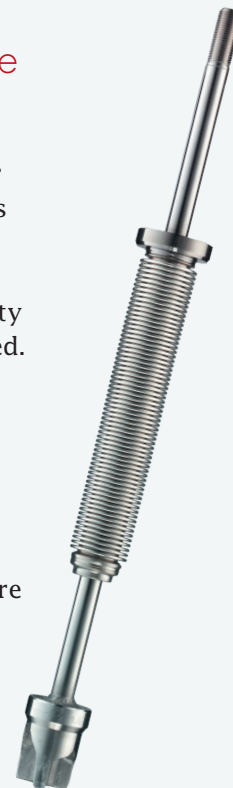

SPECIAL APPLICATIONS

Steam Service

Steam is commonly used in many plants and processes, it can however be very hard on industrial equipment. The ability to prolong the service life of valve internals in these harsh conditions is crucial to reducing costs and increasing plant productivity.

At SAMSON, we use various hardening techniques to combat these severe service applications. By making use of metal hardening, tungsten carbide, and ceramics, we are able to provide a variety of solutions to resist wear from these processes. The result is an increased valve life and a reduced total cost of ownership.

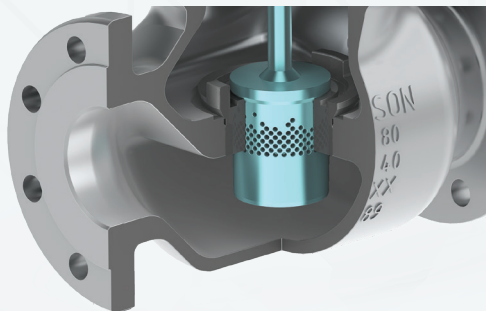

PSA (Pressure-Swing Adsorption)

High cycle counts require robust mechanical construction of valves.

- Larger stem diameters
- High strength metals
- Fast Acting
- Low Internal & External Leakage
- Bi-Directional Flow & Shutoff

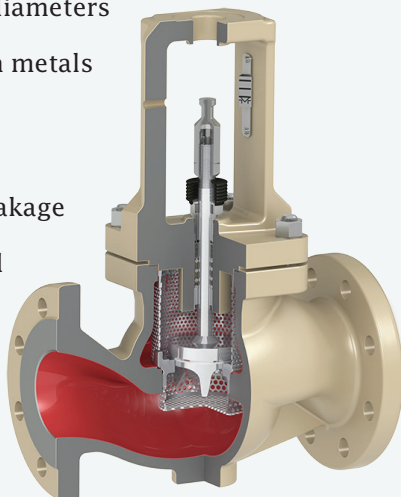

Toxic and Corrosive Processes

SAMSON valves are trusted in some of the world's most toxic and hazardous applications. From Phosgene to Hydrofluoric Acid, the 3241 can be customized to overcome the challenges of corrosive applications.



Monel, Hastelloy, Inconel, Titanium, Zirconium, Tantalum... No matter the process requirements, the 3241 valve can be built to your specifications.

Cryogenics

Applications involving high purity gases such as liquid nitrogen require a valve that can keep it's cool under demanding conditions, the 3241 valve is up to the task for controlling these processes.

When equipped with an extension bonnet, the valve is capable of operation down to -325°F (-198°C). A metal bellows seal can also be provided in these cryogenic applications when required.



TECHNICAL DETAILS

Valve Size	NPS ½ to 12
Pressure Rating	ANSI Class 125 to 300
End Connections	<ul style="list-style-type: none"> ■ Flanged: All ANSI versions ■ Welding Ends: According to ANSI B16.25 ■ Threaded Ends (Up to NPS 2, ANSI 250 Class only)
Materials	<ul style="list-style-type: none"> ■ Carbon Steel (A216 WCC, A352 LCC, & A217 WC6) ■ Stainless Steel (A351 CF8M & A351 CF3M) ■ Special materials (Monel, Hastelloy C, Duplex, etc.)
Temperature Range	-325 to 842°F (-196 to 450°C)
Internal Leakage Rate	Class IV, V, or VI according to ANSI/FCI 70-2 and IEC 60534-4
Extensions	Standard / Insulating / Bellows Seal
Packing	Spring-Loaded Low Emission V-ring Packing

SAMSON's technology has proven its value worldwide in a variety of industries. We are trusted in many of the world's most challenging applications to achieve precise control with a high level of safety and reliability.

We offer engineered solutions from a single source. With our extensive range of valves, actuators, and accessories we have the right products to suit your requirements. Our linear and rotary control valves equipped with SAMSON positioners allow seamless integration into process control systems.

Continuous investment in research and development allows us to stay at the cutting edge of technology. With over 100 years of experience and expertise, you can count on SAMSON to provide a robust solution for your application.

SAMSON
PFEIFFER · RINGO · SED · STARLINE · VETEC
 AIR TORQUE · CERA SYSTEM · LEUSCH

SAMSON Controls Inc.

4111 Cedar Blvd. Baytown, TX 77523-8588 USA
 Phone: +1 281-383-3677 · Fax: 281-383-3690



www.samsoncontrols.com



contactus@samsongroupna.com